

Installing the Balanced Body® Konnector™ Studio Reformer with Twist Lock and Metal Riser

The Konnector is compatible with Balanced Body Studio Reformers with metal risers and removable shoulder rests ONLY. If you aren't sure whether this system will work with your equipment, please contact Balanced Body at 1-800-PILATES (US and Canada), or +1-916-388-2838 (all other countries).

To view the installation podcast, please visit www.pilates.com/instructions

TOOLS REQUIRED (NOT INCLUDED):

- » Power Drill
- » Tape

PARTS LIST (INCLUDED):

ITEM	PART NO.	QTY
Konnector Rope	210-075	1
Tri-Loops (Grey)	210-061	1
Tri-Loops (Black) with pulleys	210-060	1
Konnector Metal Riser Assembly	N/A	2
Left Pulley Bracket Assembly	N/A	1
Right Pulley Bracket Assembly	N/A	1
Pulley Spring Assembly	N/A	2
Twist Lock™ Shoulder Post	616-400	2
Twist Lock Flanged Cap	616-401	2
Hair Guard	616-187	1
Bolt/Washer/Nut Assembly	N/A	2
2-3/4" Allen bolts	GEN8032	4
1/4-20x3/8" Button head screw	GEN9943	4
1/4-20x1-1/2" Flat head screw	GEN7313	2
1/4" Flat Washer	GEN9305	6
1/4" Fender Washer	GEN9952	2
1/4-20 Nylock nut	GEN9021	4
5/32" Allen wrench	GEN9282	1
3/16" Allen wrench	GEN9280	1
5/16" Drill Bit	TOL1059	1
Drill Template	607-541	1
7/16" Wrench	616-113	1

WARNING: Using the existing shoulder posts with a Konnector system can cause the loops to fall off the posts during use which may cause injury.

REMOVE ROPES, POST AND SHOULDER BRACKETS

1. Remove the ropes and loops from your Reformer, they are no longer needed.
2. Unthread each post from the shoulder rest bracket by hand and completely remove them from the shoulder rest bracket. You will no longer need them. Remove the shoulder rest bracket from the carriage. Repeat on the other side.
3. Using the provided Allen wrench, remove the two flat head screws as shown in Figure A. Replace these two removed screws with the two flat head screws (1/4"-20 x 1-1/2" long) provided.

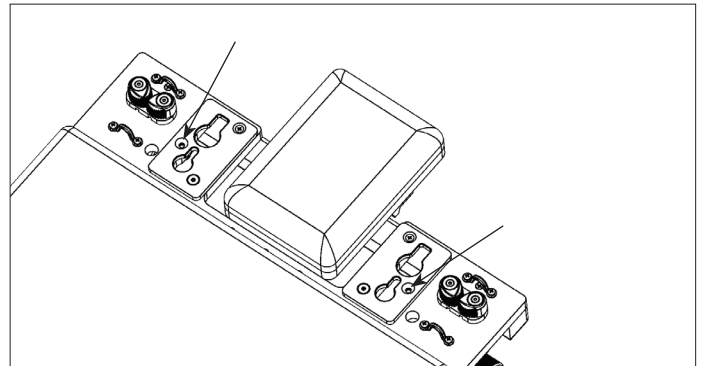
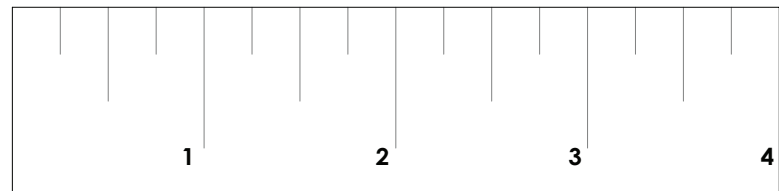

Figure A

WARNING: If you are only using some of the loops, the unused loops MUST be stored on the flanged shoulder posts.



INSTALL THE HAIR GUARD AND CARRIAGE PULLEY BRACKETS

4. Bolt the hair guard to the two carriage pulley brackets using the 1/4-20x3/8" long flanged button head screws. Make sure the threaded holes are facing inward, and the hair guard is aligned as in Figure B. Fully tighten the bolts that are through the circular holes in the hair guard, and finger-tighten the bolts that are through the slotted holes.

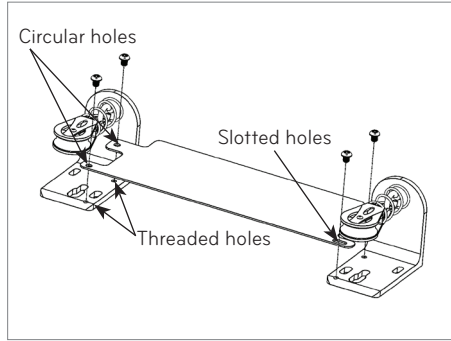

Figure B

5. Unhook all of the springs from the springbar. Lift the carriage out of the frame, turn it upside down, and rest it across the Reformer frame with the underside facing up.
6. Align the hair guard and pulley bracket assembly with holes on the underside of the carriage as shown in Figure C. Make sure the pulleys point toward the headrest. Install the 1/4" fender washer and 1/4"-20 nylon nut over the screw that protrudes up in to the pulley bracket. Finger tighten. Repeat with the other carriage pulley bracket. See Figure F for a finished view.

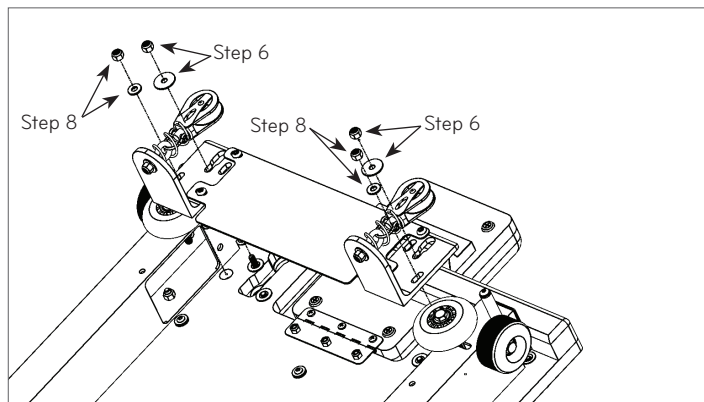

Figure C

7. Find the pre-assembled bolt, washer and nut. See Figure D.

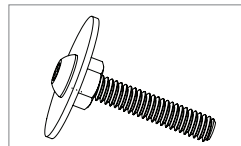

Figure D

8. Put the bolt with washer and nut into the 5/8" hole (where the original rope passed through) from the padded side of the carriage. See Figure E. It should slide through a slot in the carriage pulley bracket (refer back to Figure C). Apply a 1/4" washer and nylock nut under the carriage and finger tighten. See Figure F for a finished view.

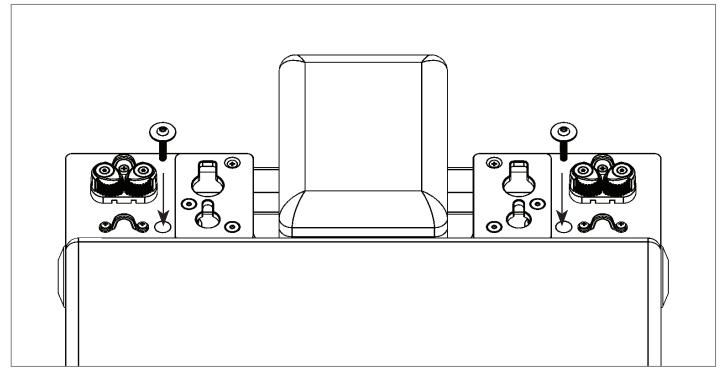

Figure E

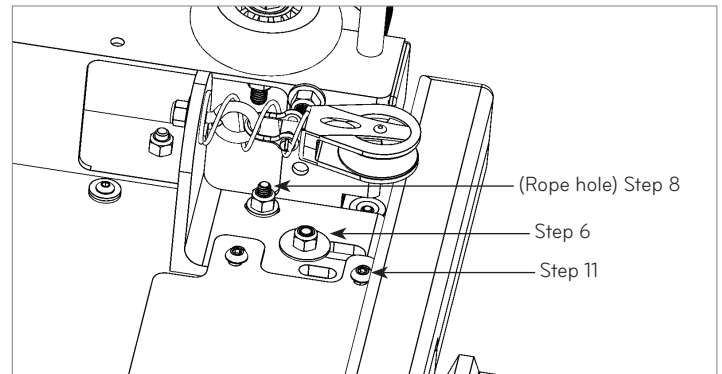

Figure F

9. Repeat steps 7 and 8 for the other carriage pulley bracket.
10. Make sure the front edge of the carriage pulley bracket is flush along the edge of the wooden beam on the carriage. Tighten all nylock nuts with a wrench (socket wrench, preferred) to secure the brackets in place.
11. Tighten the 4 button head screws to secure the hair guard to the pulley brackets.
12. Turn the carriage back over onto its wheels and place it on the rails with the headrest toward the risers.
13. Make sure the springbar is in the position closest to the foot end of the reformer ("first gear"). Attach at least one red spring to keep the carriage in place.
14. Install the shoulder rests back onto the carriage by sliding them into the slots and away from the carriage pad.
15. Install new flanged shoulder posts onto the protruding threads of the shoulder rests. Turn the flanged shoulder posts clockwise to tighten. Hand tighten so the shoulder rest does not move. Repeat on the other side. See Figure G.

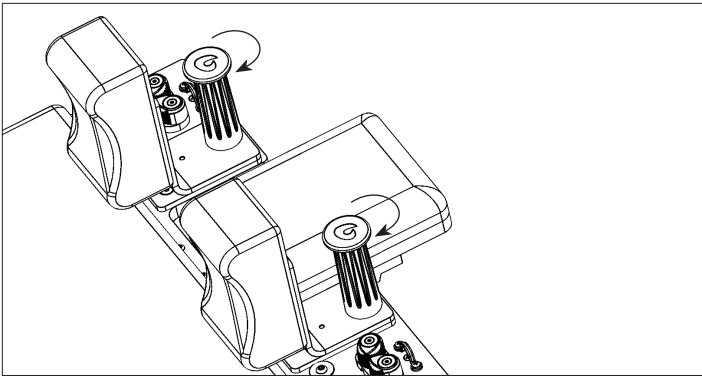

Figure G

ADDING LOWER MOUNT PULLEYS

16. Hold the drill template on the outside of the frame, in either position as shown in Figure H.

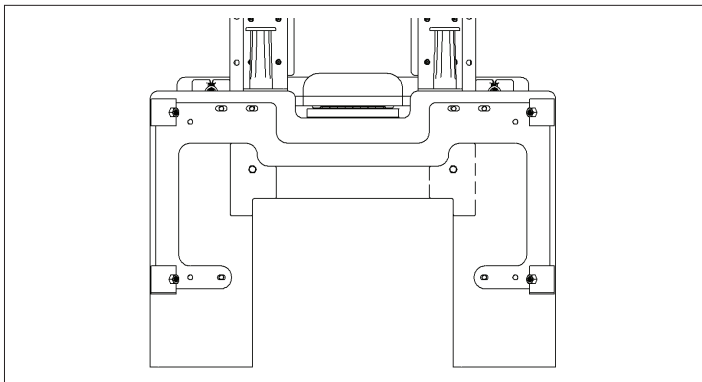

Figure H

17. If you have a tower, the top curves of the drill template will fit and match the tower bracket. If you do not have a tower bracket, the inside "L" of the template will be aligned with the inside corners of the frame.

18. Once the template is in position, tape it in place to secure it. You can also hold the template in position and mark the hole on the wood with a pencil, then remove the template to drill the marked location.

19. Using the provided drill bit, drill through the wooden frame. Remove the drill template and tape, flip it over and place on the opposite side to drill the other hole. Tape in place and drill.

20. Remove any burrs or wood splinters from both sides of the frame.

21. Install the Pulley Spring Assembly as shown in Figure J. There will be one plastic spacer on both sides of the pulley spring, one washer will be against the each side of the wood, and on the outside frame, a nut then acorn nut.

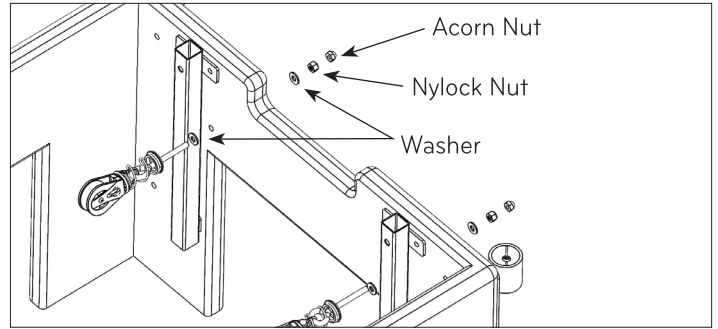

Figure J

INSTALL RISERS

22. Remove the metal risers from your existing reformer by removing the detent pins that go through the risers.

23. Install the new riser assemblies into the riser receivers and install the detent pins. See Figure K.

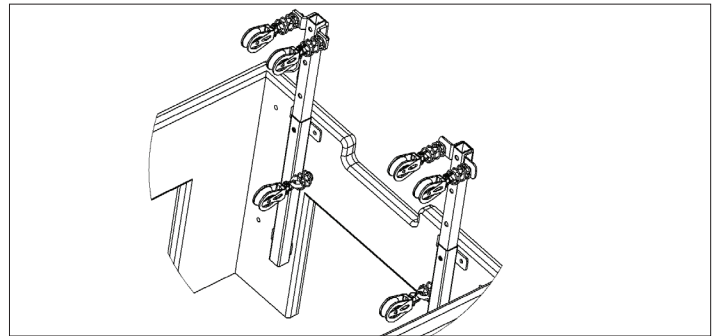

Figure K

INSTALL ROPE AND LOOPS

24. Place the black loops with pulleys on the shoulder posts. See Figure L.

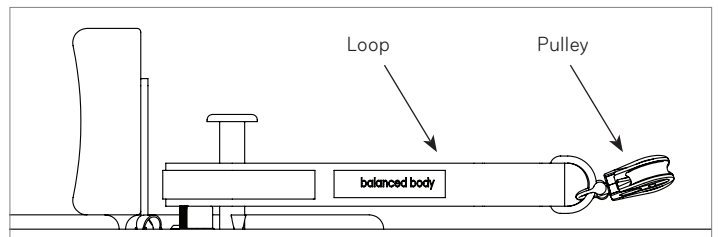

Figure L

25. Thread one end of the rope through both pulleys under the carriage and pull the ends evenly toward the risers. See Figure M.

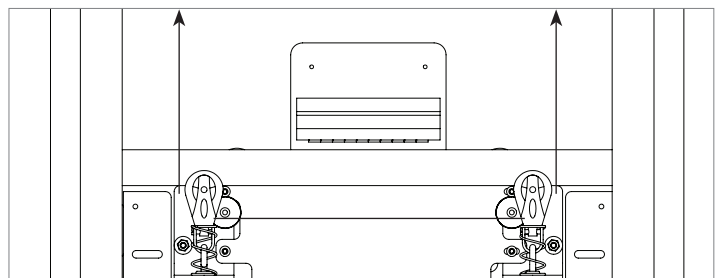

Figure M

26. Take one end of the rope and thread up through the lowest pulley on the wood frame. Continue threading the rope up through the upper, inner pulley on the riser block and pull toward the carriage. See Figure N.

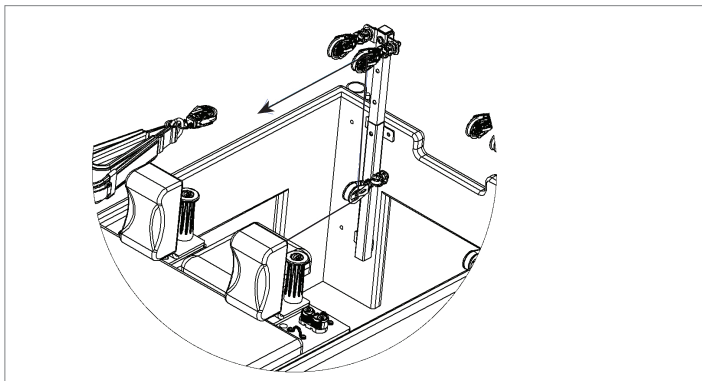

Figure N

27. Thread the rope through the pulley attached to the black Tri-Loop with pulley on the same side of the Reformer as the riser and pull back toward the riser.

28. Thread the rope through the upper, outer pulley on the riser block and pull back toward the carriage. See Figure O. See

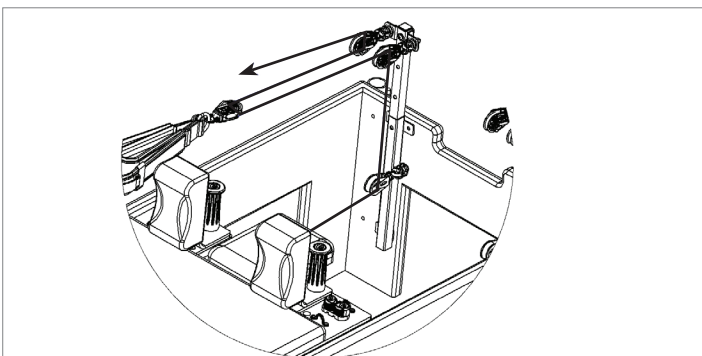

Figure O

Figure P for a detailed view of the riser pulley block rope routing.

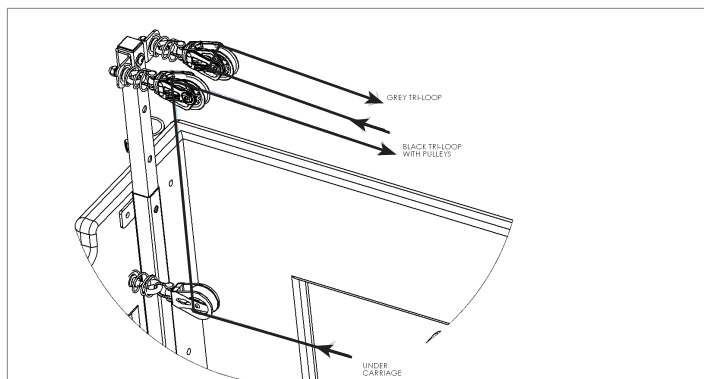

Figure P

29. Using a Soft-Touch connection, see Figure Q, secure each end of the rope to a grey Tri-Loop on the same side of the Reformer as the riser.

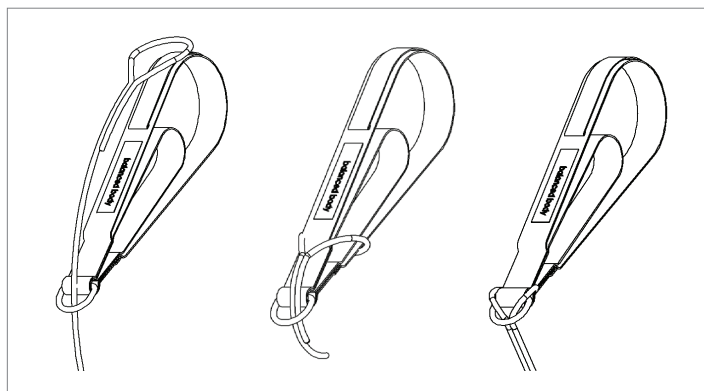

Figure Q

30. Repeat steps 27-29 for the other side of the Reformer.

IMPORTANT SAFETY NOTE: Use of the Konnector system in a manner for which it is not intended may result in equipment damage and/or injury to the user. Intense cardio work utilizing jarring movements may overload the system. Balanced Body is not responsible for injuries caused by equipment misuse.

Questions? Call Balanced Body Technical Support at 1-800-PILATES (US and Canada), or +1-916-388-2838 (all other countries).

WARNING: Using the existing shoulder posts with a Konnector system can cause the loops to fall off the posts during use which may cause serious injury.