

Assembling the MOTR™ Home from Balanced Body®

PARTS LIST (INCLUDED):

Part Number	Description	Qty
N/A	MOTR Home	1
213-063	Caster, 3 inch	4
GEN9206	Flat Washer	16
GEN9472	Screw, 1/4-20 x 3/4"	16
GEN9282	Allen wrench, 5/32"	1

1. Remove the MOTR Home from the packaging and unpack all of the other parts from inside the MOTR Home.
2. Turn the MOTR Home upside down so the caster holes are facing up as shown in Figure A.
3. Use the screws, washers, and the provided Allen wrench to secure the casters to the bottom of the MOTR Home, also shown in Figure A.
4. Turn the MOTR Home right side up and it is ready to be used!

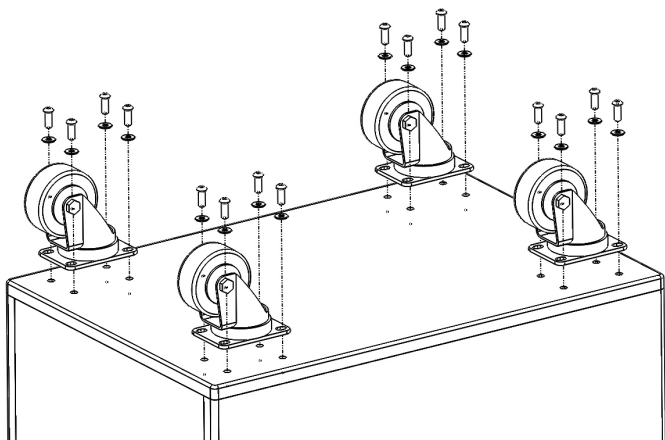

Figure A

USAGE NOTES (PLEASE READ BEFORE USING):

- » The MOTR Home is intended for use on hard floors or low pile carpet. Using it on soft or deep pile carpet may be undesirable or unstable.
- » Always stay in contact and in full control of the MOTR Home when moving it. A fully loaded MOTR Home can weigh quite a lot and caution should be used.

- » If your MOTR Home will not be fully loaded, evenly distribute the MOTRs in the various positions (i.e. do not load up one side and leave the other side empty.) An unbalanced load will make the MOTR Home unstable when being moved.

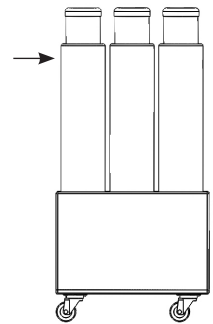

Figure B

- » MOTRs are to be loaded with the lid facing up.
- » To move the loaded MOTR Home, push on the foam portion of the loaded MOTRs. It is not recommended to push on the locking lids of the MOTRs (see Figure B).

If you have any questions, call Balanced Body at 800-745-2837 (USA and Canada) or 916-388-2838 (all other countries).